



SIEMENS



[www.siemens.com](http://www.siemens.com)



# Communications network solutions for smart grids

Answers for infrastructure & cities.



**SIEMENS**  
[siemens-russia.com](http://siemens-russia.com)

# Communications solutions are manifold – but we put it all together

A secure, reliable, and economical power supply is closely linked to a fast, efficient, and dependable communications infrastructure. The planning and implementation of communications networks require the same attention as the installation of the power supply systems themselves.



## **New challenges for energy networks ...**

As a result of the deregulation of the energy markets, the separation of the vertically integrated structures of the past, and the sharp increase in decentralized power generation, the reliable management of power supply systems is increasingly challenging. This development goes hand in hand with the rapid growth in the demand for communications. This is not just a question of higher bandwidths but also of communications requirements for new energy applications, including meter data management, distribution automation, and demand response, to name just a few examples. At the same time, energy network components like ring main units, distributed energy resources, virtual power plants, microgrids, public charging, energy storage, and private households need to be integrated into the power utilities' communications infrastructure for smart grids.

## **Evolution of communications technology ...**

In a parallel process, communications technology has continued to develop rapidly over the past few years, and Ethernet has become the established standard in the power supply sector.

International communications standards like IEC 61850 will further simplify the exchange of data between different communications partners.

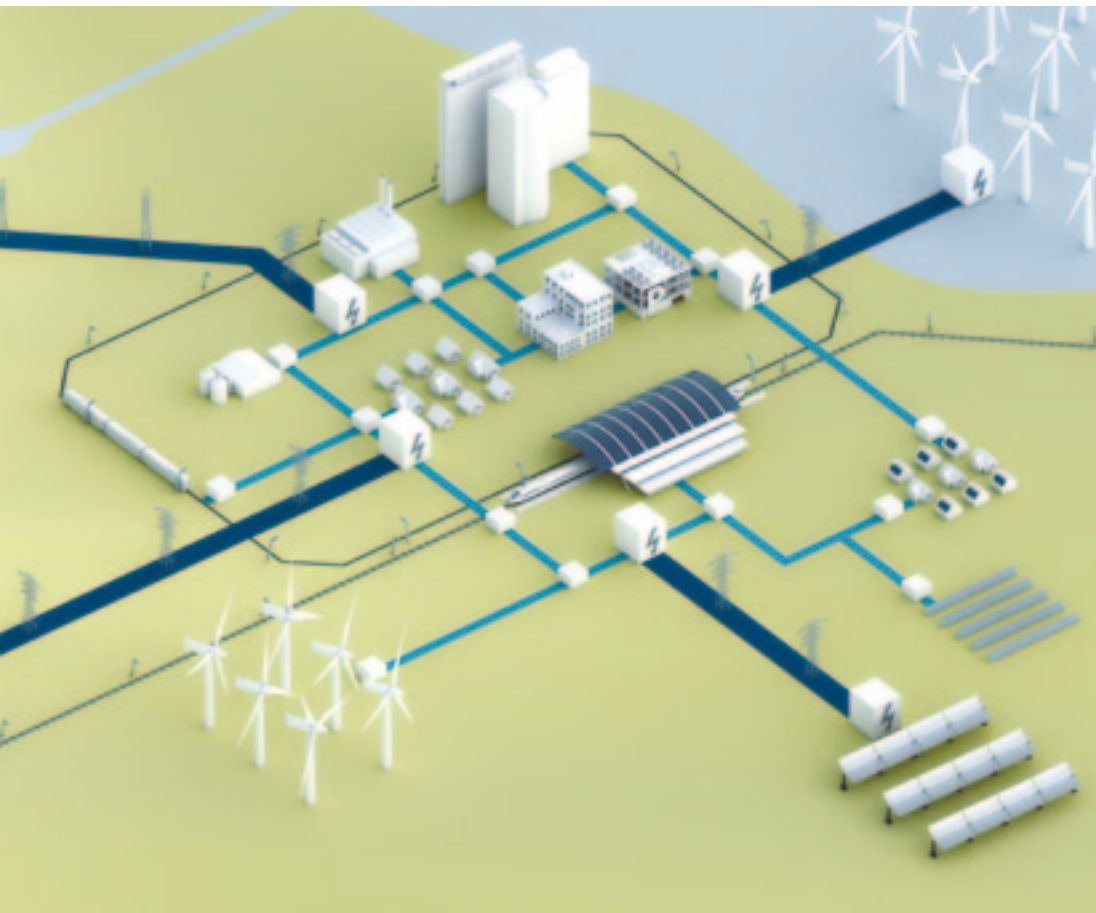

#### Your advantages at a glance:

- We offer tailored turnkey solutions for building a power utility communications network.
- We shape the future in terms of technology, standards, and solutions.
- Our customers benefit from Siemens' security expertise.
- We offer customized after-sales services.
- We provide financing models.
- Our customers benefit from Siemens' global presence and long experience in the utility industry.

#### Migration to a smart-grid communications network...

This means that the power utilities' mostly heterogeneous communications networks, with their gaps in coverage and bandwidth, need to be migrated to a smart-grid communications infrastructure. That will provide IP/Ethernet connectivity between most components. The gradual migration of most conventional communications interfaces and products toward TCP/IP-based networks and the extension of network access down to the consumer level are therefore an important task for decision makers at power supply companies. To meet these challenges, a team-oriented and interdepartmental planning of migration concepts is required.

#### We offer a tailored solution

For these communications requirements, Siemens offers customized and rugged communications network solutions for fiber-optic, power line, and wireless infrastructures based on the accepted standards of the energy industry.

Naturally, this also includes a full range of services, from communications analysis to the operation of the entire system.

Communications  
infrastructure

Fiber optics/  
SDH/Ethernet  
Power-line carrier  
Microwave  
Router, switch

Fiber optics/  
SDH/Ethernet  
BPLC  
WiMAX  
Wireless mesh  
GSM/UMTS/LTE  
Router, switch

Fiber optics  
NPLC, BPLC  
WiMAX  
Wireless mesh  
GSM/UMTS/LTE  
DSL, router, switch

# Customer-specific communications solutions required

There's a lot to do – on the journey to the grid of the future.

## Transmission – controlling long routes

### Typical applications:

- Control center monitors and controls the transmission grid and the substations
- Substations communicate with each other (e.g., if a disturbance occurs on a line)
- Use of the communications network for enterprise applications

The two proven and optimal communications technologies for application-specific needs are synchronous digital hierarchy (SDH) and Ethernet. Fiber-optic cables are used whenever it is cost-efficient. At the remote ends of the network, however, where the installation of fiber-optic cables is not economical, substations are connected using digital high-voltage power line carrier systems.

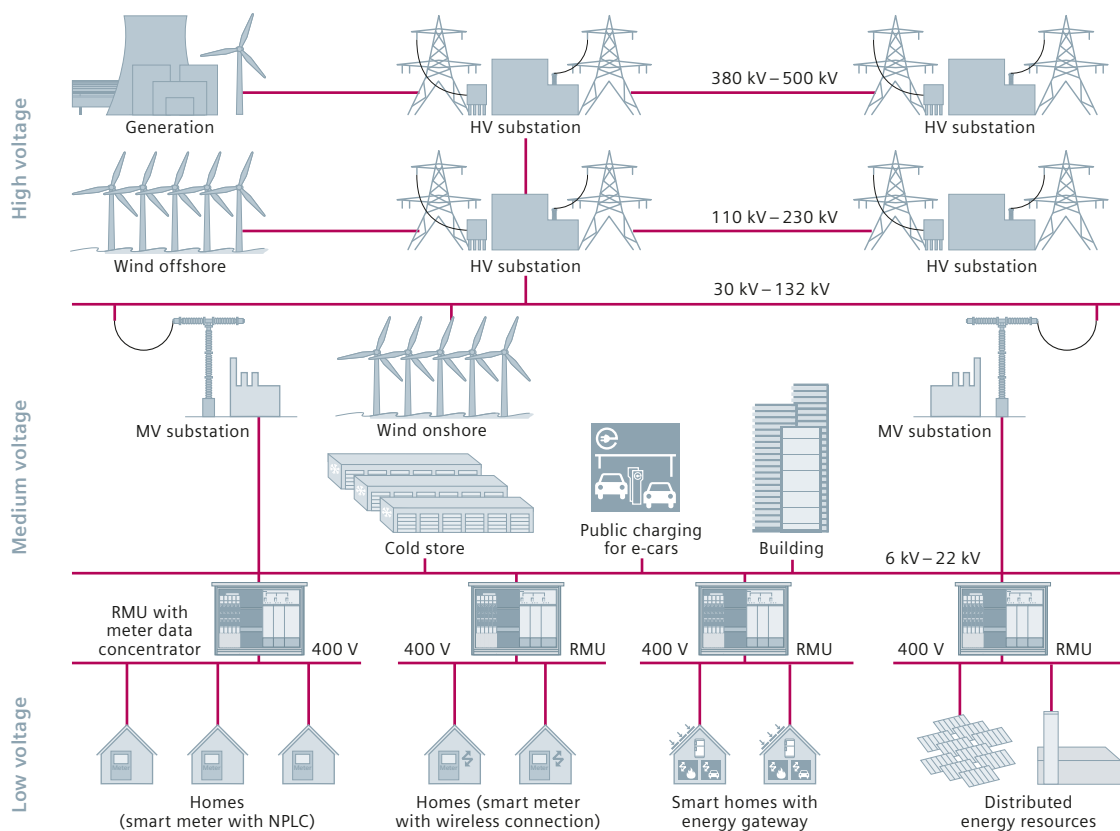

#### Applications:

- Control center (EMS/DMS)
- Virtual power plant
- Microgrid
- Distribution automation
- Condition monitoring
- Demand response
- Marketplace
- Asset management
- Meter data management
- E-car operation center
- etc.

#### Distribution – fluctuating infeed – secure supply

The situation in the distribution network is quite different. While subtransmission and primary substations also include digital communication, lower distribution levels have very weak communications infrastructures.

In most countries, less than 10 percent of transformer stations and ring main units (RMU) are monitored and controlled remotely.

The rapid increase in distributed energy resources today is impairing the power quality of the distribution grid. That's why grid operators need to be able to respond quickly in critical situations. A prerequisite for this is the integration of the key ring main units and the volatile decentralized wind and solar generation into the energy management system, and thus into the communications network of the power utilities.

Because the local environment differs widely, it is crucial that the right mix of the various communications technologies is deployed. This mix will need to be exactly tailored to the utilities' needs and the availability of the necessary infrastructure and resources (e.g., availability of fiber-optic cables, frequency spectrum for wireless technologies, or quality and length of the power cables for broadband power line carrier).

#### Consumer access – rapid rise in requirements

- Exchange of conventional meters with smart meters, which provide bidirectional communications connections between the consumer and energy applications (e.g., meter data management, marketplace, etc.)
- Management of consumers' energy consumption using price signals, as a response to the steadily changing energy supply of large distributed producers
- If a large number of small energy resources are involved, the power quality of the low-voltage grid must be monitored, because the flow of current can change directions when feed conditions are favorable

The selection of a communications solution depends on the customer's requirements. If only meter data and price signals are to be transmitted, narrowband systems such as narrowband power line carriers or GPRS modems are sufficient. For smart homes in which power generation and controllable loads (e.g., appliances) or e-car charging stations are to be managed, broadband communications systems such as fiber-optic cables, broadband power line carriers, or wireless solutions are necessary.



# Distribution networks

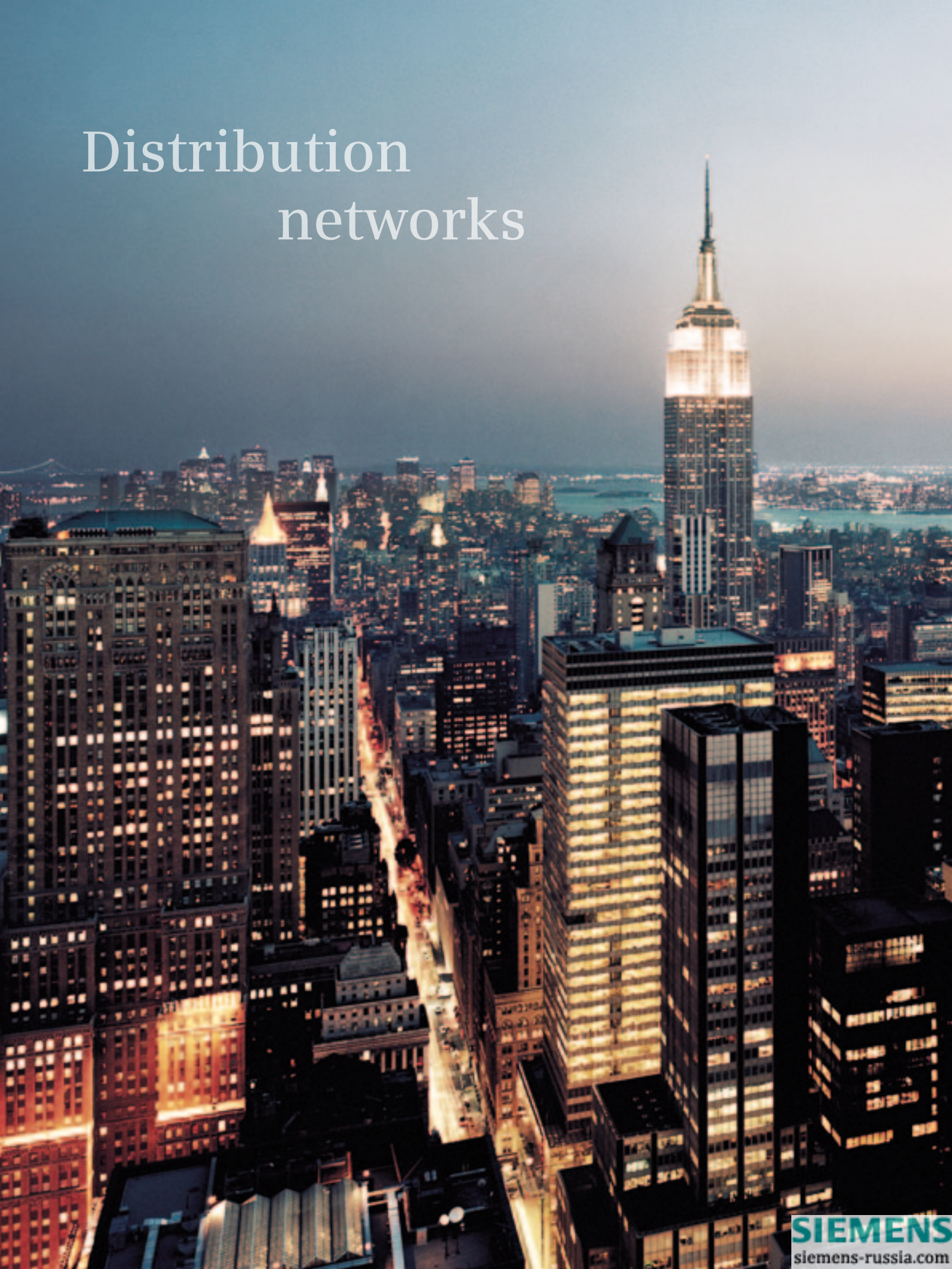

# Power for large areas – communication along the entire distribution network down to the consumer access level

In the past, electricity was mainly produced by bulk generation at central locations and distributed to consumers via the distribution grid. Energy peaks (e.g., at midday) were well known and balanced out by reserve capacity of central power plants. It was therefore usually not necessary to specially control the lower-level distribution grids, or even to integrate the consumers into the grid monitoring system.

Ever since renewable energy has been significantly expanded, electricity is being fed into both the medium-voltage and low-voltage grids, depending on changing external conditions (e.g., weather, time of day, etc.).

These fluctuating energy resources can severely impair the stability of the distribution grid.

One of the key challenges of a smart grid therefore is quickly balancing out the energy supply and energy consumption in the distribution grid.

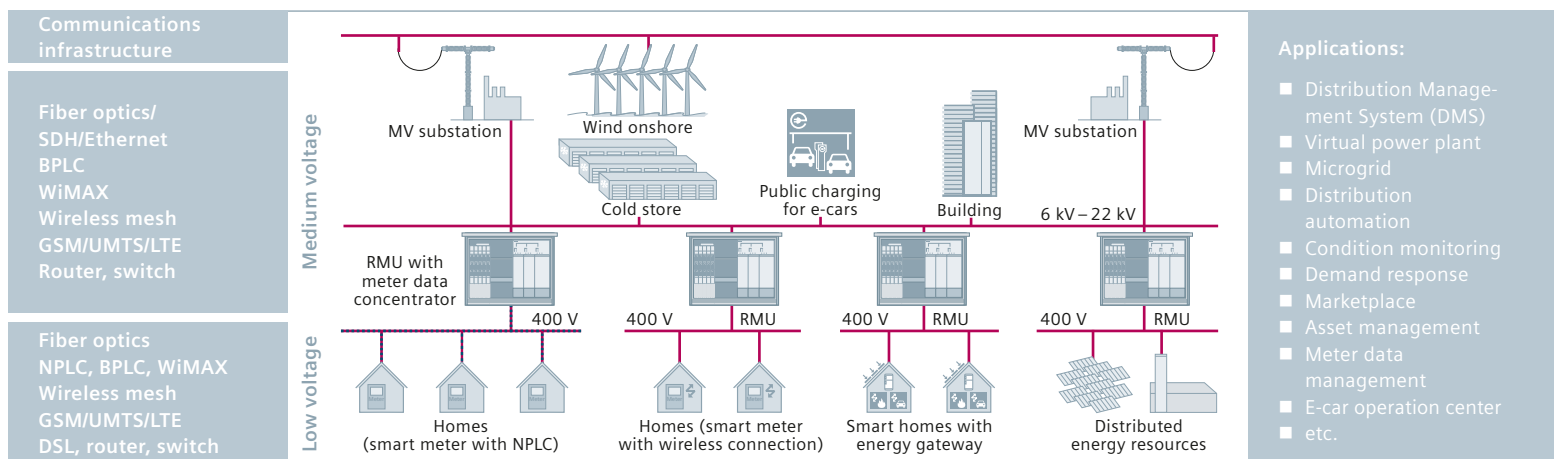

Typical energy distribution network integrating ring main units, consumers, prosumers, distributed energy resources, etc.



# New challenges for the operation of distribution grids

A prerequisite for implementing a solution for this demand is monitoring and managing as many components of an energy grid as possible all the way to the consumer. The basis for this is a reliable communications infrastructure.

For medium voltage, at least the following network components must be integrated into a smart grid and managed:

- The key ring main units
- All large distributed producers (solar/wind farms, biogas/hydroelectric power plants, etc.)
- Large buildings, campuses, refrigerated warehouses, etc.

For low voltage, primarily households and small producers of renewable energy are involved.

With respect to their role in the energy grid, consumers can be divided into two groups:

- "Standard consumers", who have smart meters and optimize their electricity costs via ongoing price signals depending on supply and demand
- "Prosumers" (prosumer = producer + consumer), who can feed surplus energy into the grid – such as solar power or energy generated by combined heat and power systems (CHP); many can also intermediately store energy using possibilities such as night storage heaters or e-cars.

While the communications requirements for standard consumers are concentrated on smart metering including price signals, time-critical control signals and power quality data must also be transmitted for prosumers. Therefore, in addition to smart meters, prosumers have energy gateways, which process and forward these control signals accordingly.

## Communications infrastructures for all conditions

The communications infrastructure in the medium- and the low-voltage distribution grids is usually a heterogeneous system and the suitable technologies depend to a large extent on the local topology (large city, rural region, distances, etc.). It must therefore be specifically tailored for each customer.

In general, the following communications technologies are available:

- Fiber-optic or copper cables are the best option, if present
- Narrowband power line carrier (NPLC) systems for transmitting meter data; they are frequently already integrated into the smart meters
- Broadband PLC systems offering IP connectivity with > 1 Mbps
- Setup of own private wireless networks (e.g., wireless mesh, private WiMAX), when spectrum is available at reasonable prices or local regulations allow for it
- Public wireless networks, depending on the installation for narrowband communication in the kbps range (e.g., GPRS) or in the future in the Mbps range (LTE, WiMAX providers). Attractive machine-to-machine (M2M) data tariffs and robust communication in case of power outages are key ingredients to make this communications channel a viable option.

Depending on the applications being installed inside the RMU, an Ethernet switch/router might be needed in order to concentrate the communications flow. These data concentrators can be implemented as custom solutions or integrated, for example, in the RTU (remote terminal unit).

To meet these requirements, Siemens offers a full range of all above-mentioned communications technologies including rugged switches and routers that comply with energy industry standards.

## Benefits:

- Customer-specific overall communications solution, optimized for the respective local conditions
- Partnering with Siemens – benefiting from a high level of technical expertise in both the energy and communications sectors



## Fiber optics

### The best choice for all communications needs

Fiber optics is the best transmission medium for medium- and low-voltage applications because it is robust and not susceptible to electromagnetic disturbances or capacity constraints. That's why grid operators who choose this technology will be well prepared when their communications needs multiply in the future.

Fiber-optic cables are laid underground to connect individual substations. This work is associated with heavy civil works, and therefore with great expense. However, when new power cables are installed the cost-benefit analysis paints a clear picture. Fiber-optic cables should generally be the first choice in this case.

#### Benefits in detail:

- At the core of a variety of communications systems, from passive optical networks (PON) to Ethernet and SDH
- Durable, insusceptible to electromagnetic disturbances
- Practically unlimited transmission capacity

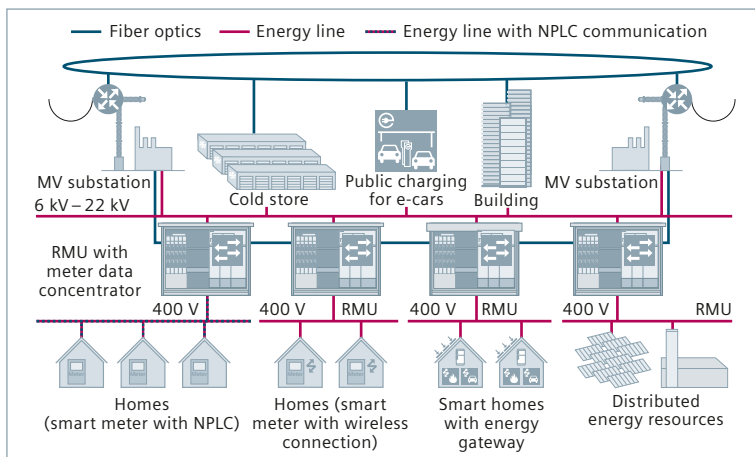

Fiber-optic infrastructure for distribution network

## Broadband power line carrier

### For low- to medium-voltage applications, using the existing power line

BPLC is an attractive alternative for many applications in medium- and low-voltage smart-grid scenarios.

It uses the utility-owned infrastructure in the distribution network, and thus has no continuous OPEX for the communications channel (operational expenditure) – and therefore it is especially useful for connecting elements in the grid where there are no other communications media available.

Battery buffers allow the use of remote control with automation systems, even in cases of power loss.

Initially, the BPLC uses the medium-voltage lines between the distribution substation and the transformer stations as a communications infrastructure for process control in the medium-voltage domain.

In addition, the BPLC can use low-voltage lines as a communications infrastructure for applications linking the transformer stations and consumers/households (for example, the integration of smart homes). The BPLC modules feature both IP and RS 232 interfaces, and can therefore be used flexibly for diverse communications applications. Transmission range and bandwidth are heavily depending on the quality and the age of the power cable. As a rule of thumb, if the bandwidth in MV grids is in the range of 10 Mbps, a distance of approximately 1 km is possible.

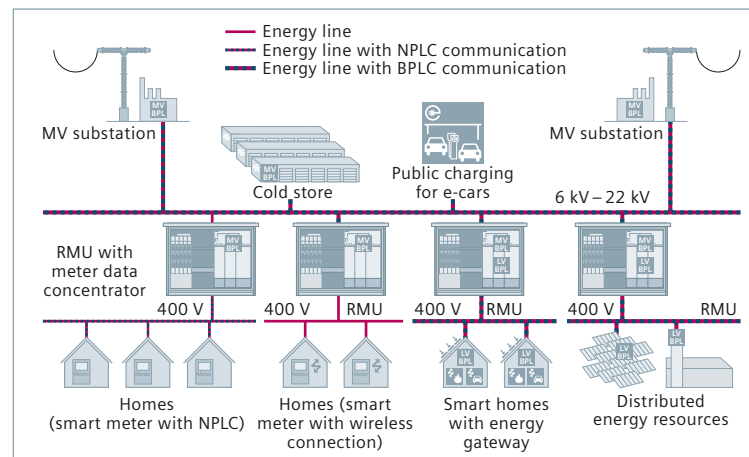

Broadband power line carrier for medium- and low-voltage applications

## WiMAX

### For RMU backhaul and prosumers

The main application area for WiMAX is considered to be RMU backhaul. It also serves to connect scattered consumers or endpoints with more demanding communications requirements – in other words, prosumers.

WiMAX (worldwide interoperability for microwave access) is a standards-based telecommunications protocol (IEEE 802.16 series) that provides fixed and mobile broadband connectivity. Originally designed as a wireless alternative to fixed network broadband Internet access, it has evolved over the past ten years into an advanced point-to-multipoint system that also supports mobile applications like workforce management. The technology is field-proven, globally deployed, and continues to evolve. WiMAX networks can be scaled from small to large, which allows for privately owned networks even on regional and local levels.

Detailed requirements as well as specific regional conditions and spectrum availability must be carefully assessed in order to select the best-suited technology and product combination from a wide variety of options.

#### Basic technical data:

- Average data rate: ~10 Mbps; can be extended with IEEE 802.16m to over 50 Mbps
- Average coverage: up to 10 km in non-line-of-sight and up to 30 km in line-of-sight conditions
- Radio spectrum in licensed or license-exempt frequency bands

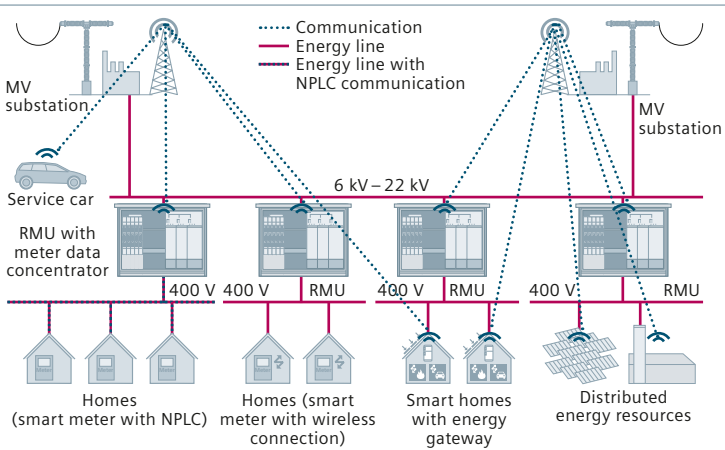

WiMAX network

## Wireless mesh

### From consumer access to RMU backhaul

The applications for wireless mesh networks stretch from the consumer access to the RMU backhaul. Wireless mesh networks are composed of cooperating radio nodes organized in a mesh topology. The underlying technology for communication from one hop to another can be standardized (for example, the IEEE 802.11 series [Wi-Fi] or IEEE 802.15.4 [low-rate wireless personal area network, LoWPAN]) or proprietary (for example, U.S. 900-MHz technologies). The mesh protocols and corresponding routing mechanisms are, on the other hand, more recent developments and therefore are still predominantly proprietary. Thanks to their mesh properties along with self-setup and self-healing mechanisms, mesh networks inherently offer ease of operation and redundancy for fixed applications – but performance is limited in terms of either coverage or bandwidth.

Detailed requirements as well as specific regional conditions must be carefully assessed in order to select the best-suited technology.

#### Basic technical data:

- Average data rate per hop: from ~100 kbps (U.S. 900-MHz) up to ~10 Mbps (Wi-Fi); net data rates per hop decrease with increasing number of hops
- Average range hop-to-hop: ~1 km nLoS/~5 km LoS (U.S. 900-MHz); ~100 m nLoS/~1 km LoS (Wi-Fi) coverage extension by means of mesh
- Radio spectrum primarily in license-exempt frequency bands

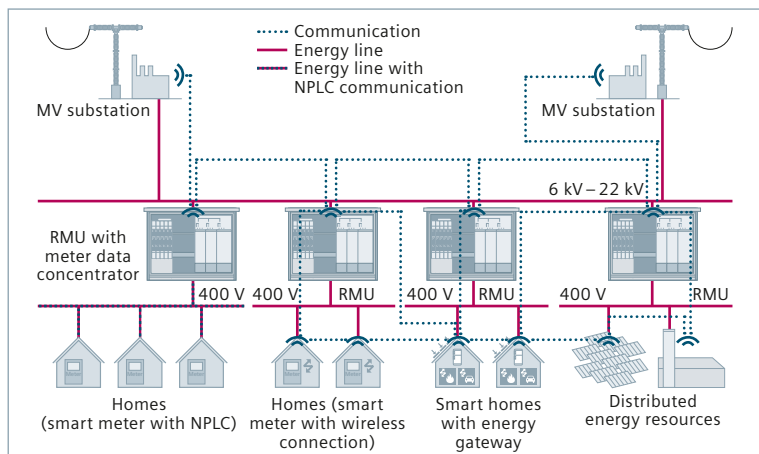

Wireless mesh network

## Public cellular networks

### For the extension of private communications networks

The main application areas for public mobile radio networks in the smart-grid context are meter reading and energy grid monitoring functions.

In contrast to constructing new, proprietary networks for smart-grid communication, there is also the option of using existing cellular radio networks owned by communications service providers. These networks are standards-based, deployed worldwide, and continuously upgraded and expanded. Activities like acquiring spectrum licenses, building, operating, and maintaining the network as well as assuring sufficient coverage and bandwidth on a nationwide scale are naturally managed by the communications service providers. Data rates normally available range from 50 kbps (GPRS), over 10 Mbps (HSPA), to over 50 Mbps (upcoming LTE). Attractive data tariffs and the availability of the network are key to use public cellular networks for smart-grid applications.

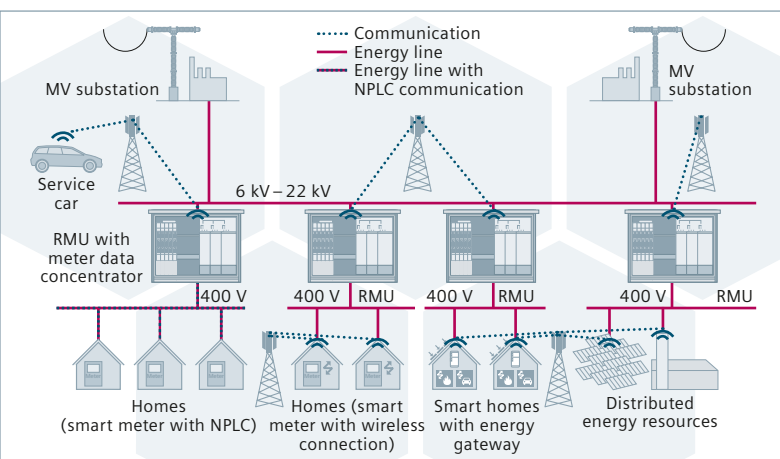

Public cellular network





# Transmission networks



# Along hundreds of kilometers – monitoring and controlling long-distance high-voltage lines across the transmission network

Our 80 years of experience with communications solutions for high-voltage lines is unparalleled. Our first power line carrier system started operations in the early 1930s.

Today, the communications infrastructure that runs along the long-distance power transmission lines is normally based on fiber-optic cables.

Siemens offers complete communications solutions for high-voltage grids consisting of the following:

- SDH/Ethernet systems
- Teleprotection system
- Power line carrier system

## Synchronous digital hierarchy (SDH)/ Ethernet solutions

### Field-proven communications backbone technology

For communication at transmission and subtransmission levels, Siemens offers the latest generation of SDH (synchronous digital hierarchy) equipment, commonly referred to as NG (next-generation) SDH.

NG SDH technology combines a number of benefits that make it well-suited to the needs of energy utilities. Among those benefits are high availability, comprehensive manageability, and monitoring features, and last but not least SDH's unique ability to seamlessly support both legacy applications and new, primarily packet-based emerging standards.

Ethernet-over-SDH provides the capacity to transport packet-based traffic over the SDH backbone with high reliability and low latencies. As a result, Ethernet-over-SDH is the solution of choice for enabling IEC61850 across the entire communications backbone.

State-of-the-art NG SDH systems are highly integrated, providing all of the above-mentioned capabilities in a single device. In order to address the varying needs and requirements of the energy utilities, Siemens offers a wide range of products, from a single-board CPE to a multiservice platform for PDH (plesiochronous digital hierarchy), SDH, WDM (wavelength division multiplexing), and Ethernet.

#### Benefits at a glance:

- High availability
- Very short delay times in protection signal transmission
- For both legacy and packet-based applications/systems
- Supports IEC 61850 standard
- Full-spectrum network management system

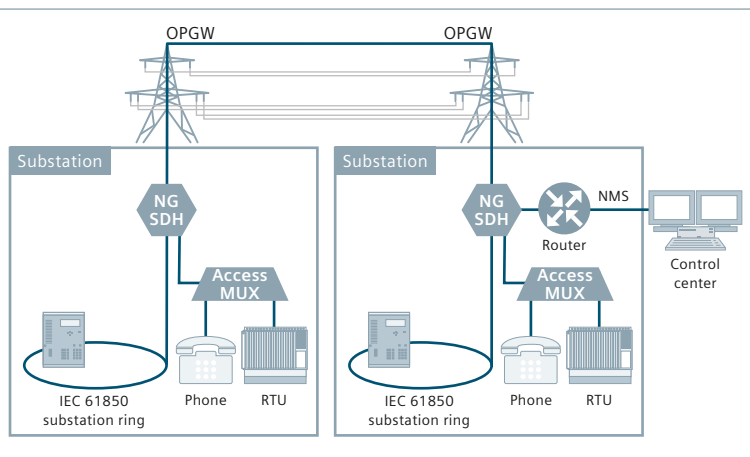

Typical high-voltage SDH communications network

## PowerLink – power line carrier for high-voltage lines

### No separate communications cable required

PowerLink uses the high-voltage line between transformer substations as a communications path for data, protection signals and voice. This technology, which has been tried and tested over decades and adapted to the latest standards, has two main application areas:

- as a communications link between substations where a fiber-optic connection does not exist or would not be economically viable, and
- as a backup system for transmitting protection signals parallel to an installed fiber-optic link.

Thanks to the continuous development of this technology, it remains as important as ever. Over long distances with relatively low data volumes, PLC is still hard to beat in terms of cost-effectiveness.

PowerLink provides the highest communications standards for power network protection. Its smooth integration into other types of communications technology like fiber-optic and satellite links opens the door to a variety of new features and functions. With its ability to switch from analog to digital transmission, it can work with both transmission modes at the same time.

#### The advantages:

- Cost-effective for small to medium data volumes over long distances
- Use of utility-owned resources (power lines)
- Highest reliability (for example, for protection signaling)
- Can be used in effective combination with broadband technologies for highest availability

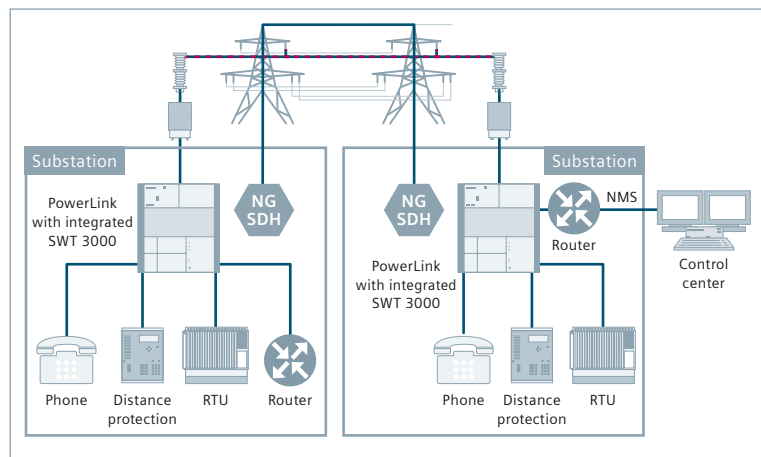

Typical high-voltage PowerLink communications network as backup for SDH communications network

## SWT 3000 – teleprotection for high-voltage lines

### To quickly identify, isolate, and resolve network failures

The SWT 3000 Teleprotection system is the highly developed solution worldwide for identifying and isolating faults extremely quickly in the high-voltage grid. Combined with existing distance protection relays, it allows operators to reduce downtime to an absolute minimum. The current stage of development is based on 50 years of practical experience and adaptation to changing challenges. A proven technology that is continuously being refined to meet future needs.

The SWT 3000 protection signaling system is extremely versatile. For example, it can use analog and digital networks as communications infrastructure. At the same time, it's ideal for establishing substation-to-substation communication via IEC 61850.

### A closer look at the migration of existing substations

The SWT 3000 also demonstrates its high degree of flexibility when existing substations are migrated to protection devices via the IEC 61850 communications standard. The SWT 3000 has all necessary command interfaces – both as binary interfaces and as GOOSE. This always keeps investment costs economically manageable, because the substations can be updated step by step for a new network age.

### SWT 3000 as a binary command interface

The Siemens SWT 3000 with bidirectional individual channels for direct, permissive or blocking applications, offers the connection of traditional distance protection devices based on binary input and output commands.

### SWT 3000 for IEC 61850 (GOOSE)

When distance protection is already operating with IEC 61850 interfaces, GOOSE commands can be transmitted via SWT 3000 from substation to substation via electrical or optical ports.

### The advantages:

- Keeps downtimes to an absolute minimum
- Supports IEC 61850 interfaces as well as conventional binary interfaces
- Flexible integration into various customer communications networks
- Path protection via two different transmission routes for increased reliability

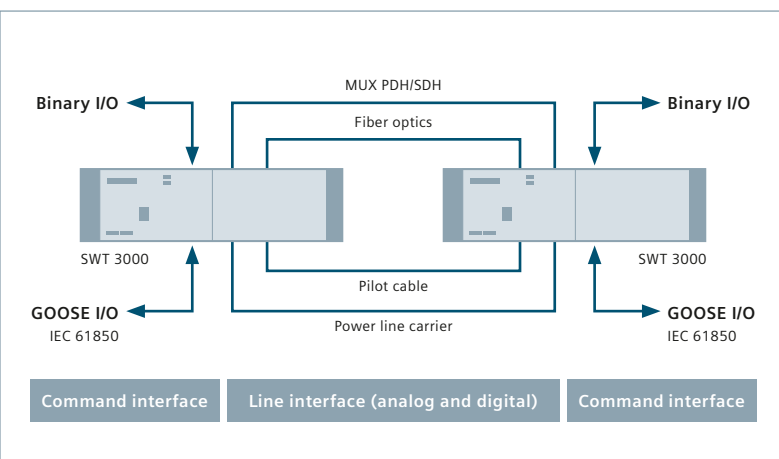

SWT 3000: wide range of command and line interfaces

**Published by and copyright © 2011**

Siemens AG  
Infrastructure & Cities Sector  
Smart Grid Division  
Services  
Humboldtstr. 59  
90459 Nuremberg, Germany

For more information, please contact our  
Customer Support Center  
Phone: +49 180/524 70 00  
Fax: +49 180/524 24 71  
(Charges depending on provider)

E-mail: [support.energy@siemens.com](mailto:support.energy@siemens.com)

Order No. E50001-G720-A151-V3-4A00 | Printed in Germany |  
Dispo No. 06200 | c4bs No. 7458 |  
GB 110638 482667 | WS | 11111.0

Printed on elementary chlorine-free bleached paper.

All rights reserved.  
Trademarks mentioned in this document are  
the property of Siemens AG, its affiliates, or their  
respective owners.

Subject to change without prior notice.  
The information in this document contains general  
descriptions of the technical options available,  
which may not apply in all cases. The required  
technical options should therefore be specified  
in the contract.